

Fronius KASAMAS *Speedglas* parweld SOLTER Kjellberg

Ádám és Ádám Kft

HEGESZTÉSTECHNIKA
FÉMSZÓRÁSTECHNIKA

Székhely: 4400 Nyíregyháza, Ószőlő út 99. Telephely: 4400 Nyíregyháza, Rákóczi út 102.
Tel.: +36 42 504-093, +36 42 504-094, +36 20 9449-003, +36 20 9555-417 Fax.: +36 42 504-095
E-mail: info@adam-adam.hu Weblap: www.adam-adam.hu Webshop: shop.adam-adam.hu

TTG 2600 A

- (D) Ersatzteilliste
WIG-Handsweißbrenner
- (GB) Spare Parts List
TIG Manual welding torch
- (F) Liste de pièces de rechange
chalumeau manuelle TIG
- (I) Lista parti di ricambio
cannello di saldatura WIG
- (E) Lista de repuestos
Soplete para soldadura manual
TIG
- (P) Lista de peças sobresselentes
Queimador de soldadura MIG

www.fronius-hegesztogep.com

Ádám és Ádám Kft

4400 Nyíregyháza, Rákóczi út 102

Tel.: +36 42 504 093 +36 20 9449 003

4,035,742 **TTG2600A F / 4m / 13,1ft**
4,035,743 **TTG2600A F / 8m / 26,2ft**

4,035,744 **TTG2600A F / UD / 4m / 13,1ft**
4,035,745 **TTG2600A F / UD / 8m / 26,2ft**

4,035,750 **TTG2600A F / JM / Le / 4m / 13,1ft**
4,035,751 **TTG2600A F / JM / Le / 8m / 26,2ft**

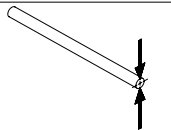
	Ø mm	Ø inch
	1,6-6,4	0,063-0,252



TTG 2600A F/UD/JM/Le

Ersatzteilliste / Spare parts list / Listes de pièces de rechange / Lista de repuestos / Lista de peças sobresselentes / Lista dei Ricambi

STANDARD

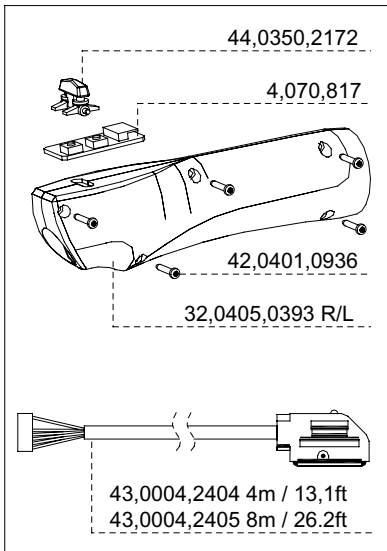

UP/DOWN

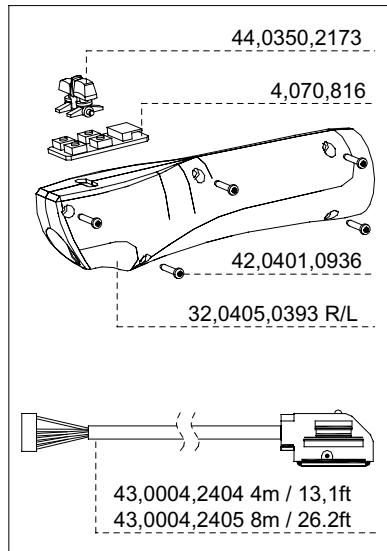

JOBMASTER

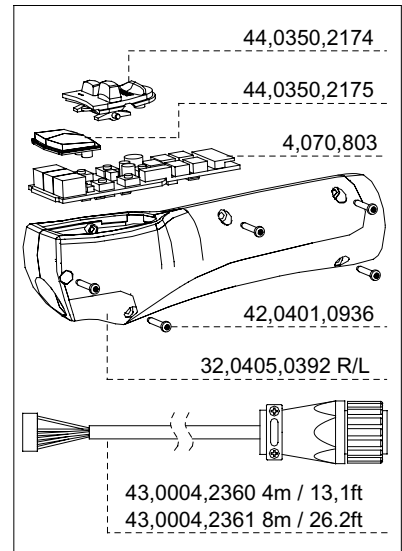

44,0350,2176 4m / 13,1ft / 44,0350,2177 8m / 26,2ft

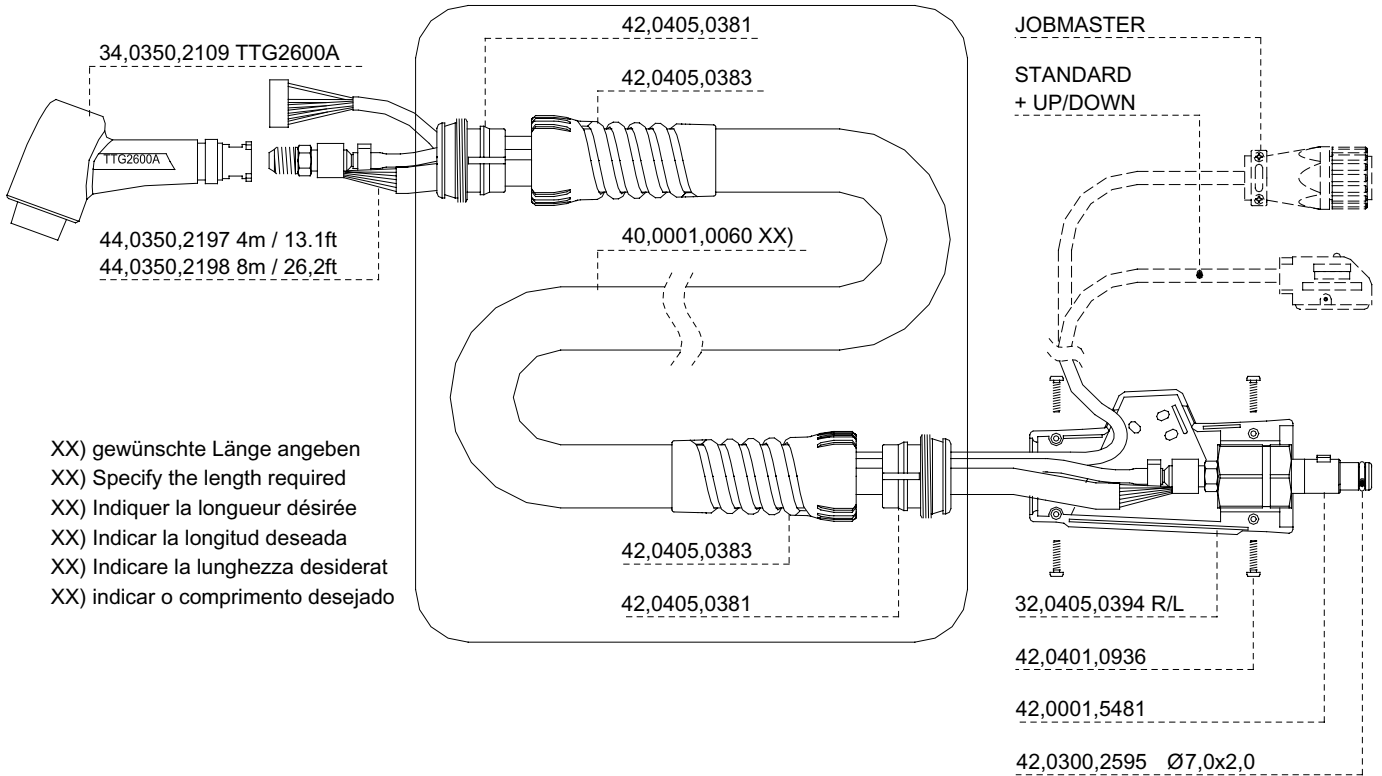

XX) gewünschte Länge angeben
 XX) Specify the length required
 XX) Indiquer la longueur désirée
 XX) Indicar la longitud deseada
 XX) Indicare la lunghezza desiderat
 XX) indicar o comprimento desejado

OPTION - Leder / Leather / Cuir

44,0350,2180 4m / 13,1ft / 44,0350,2181 8m / 26,2ft

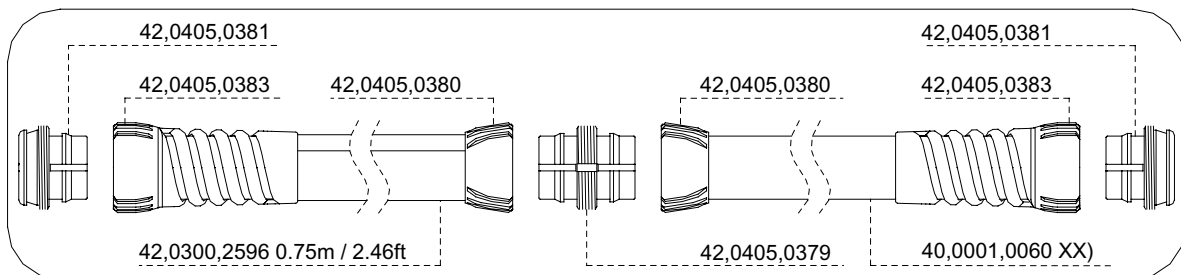

TTG 2600A F/UD/JM/Le

Ersatzteilliste / Spare parts list / Listes de pièces de rechange / Lista de repuestos / Lista de peças sobresselentes / Lista dei Ricambi

Part No. clamping nut	Part No. collet	Part No. electrode WC20	Part No. electrode WP	Electrode Ø	
				Ø mm	Ø inch
42,0001,2278	42,0001,2276	42,0411,4001	42,0411,4008	1,6	0,063
42,0001,2279	42,0001,2277	42,0411,4002	42,0411,4005	2,4	0,094
42,0001,2272X)	42,0001,2268X)	42,0411,4003X)	42,0411,4006	3,2	0,126
42,0001,2273	42,0001,2269	42,0411,4013	42,0411,4007	4,0	0,157
42,0001,2274	42,0001,2270	42,0411,4014	42,0411,4009	4,8	0,189
42,0001,2275	42,0001,2271	42,0411,4015		6,4	0,250

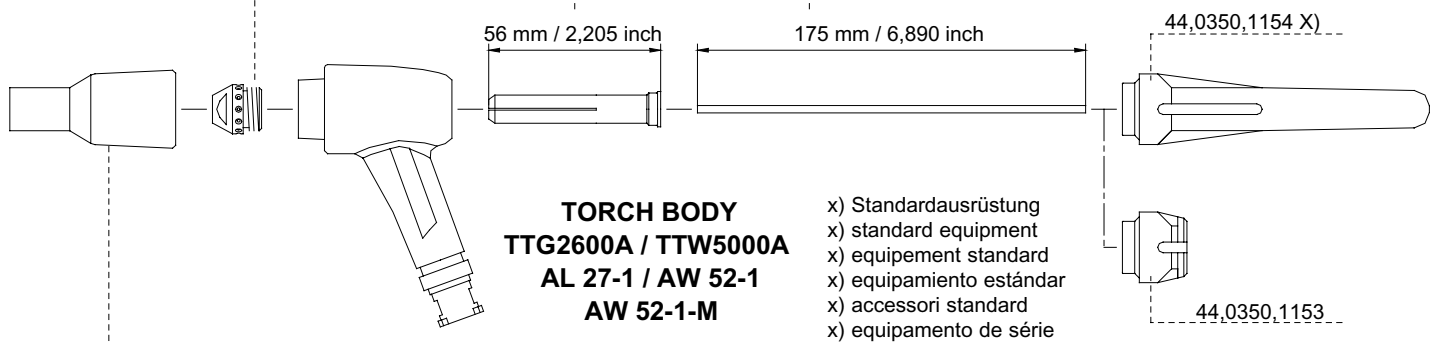

gas nozzle ceramic plugable	L1		d1		d2		Part No.
	mm	inch	mm	inch	mm	inch	
	54	2,125	26.2	1,031	7,9	0,3125	42,0300,0707
					9,5	0,375	42,0300,0708
					11,1	0,4375	42,0300,0709 X)
					12,7	0,500	42,0300,0710
					15,9	0,625	42,0300,0711



TTG 2600A F/UD/JM/Le

Ersatzteilliste / Spare parts list / Listes de pièces de rechange / Lista de repuestos / Lista de peças sobresselentes / Lista dei Ricambi

3/3

www.fronius-hegesztogep.com

Ádám és Ádám Kft

4400 Nyíregyháza, Rákóczi út 102

Tel.: +36 42 504 093 +36 20 9449 003

FRONIUS INTERNATIONAL GMBH

Froniusplatz 1, A-4600 Wels, Austria